

VCA HEADPHONE AMPLIFIER 4 OUT

SERVICE / INSTALLATION

Serial No

MANUFACTURED BY
C H I L T O N



The Chilton Voltage Controlled H.P. Amplifier allows balanced or unbalanced stereo line inputs with MASTER VOLUME control and MONO select to 4 separate stereo output jacks with VOLUME level control.

The source signal is normally connected to the rear XLR inputs or front panel jack sockets, the latter has priority, outputs are either by front panel jack sockets or rear XLRs. See Flow Diagram.

Each VCA can be controlled from 3 summing inputs.

1. Front panel Volume.
2. Remote port for each stereo output.
3. Remote port for master control of all outputs.

Normally the master volume control is turned fully up and is adjusted for very high input levels, maximum input +26dBs.

1. Can be used as manual VOLUME control or limit level to headphones.

2. Used by either control-room to adjust level or headphone user preference.

3. Allows remote setting of maximum level or fade of all outputs simultaneously from level set by front panel Volume control.

The REMOTE PORT 15way 'D' connector allows 4 stereo and 1 master each with 3 wire connections to a standard 10k ohm linear potentiometer or fader. No additional common or supply is required. Each has a separate 5 volt regulator with 100 ohm limit resistor.

SPECIFICATION:

Measurement @ 0.25 Watts RMS with 40 ohm load.

Power Response 20Hz to 20kHz +/- 1dB.

Distortion @ 100Hz to 10kHz <0.03% THD mainly 2nd.

Gain total +16dB with internal jumper +26dB.

Output Noise -90dBu 20Hz to 20kHz.

Audio Curve 5dB per division 3 to 9. Total 80dBs.

Summing Amplifier Limiter to VCA Port giving -90dB Max.

Power Supply Regulated +/- 15volts Dc with current limit.

Power Input 115/230volts Ac 50/60Hz. Fused 200mA A.S.

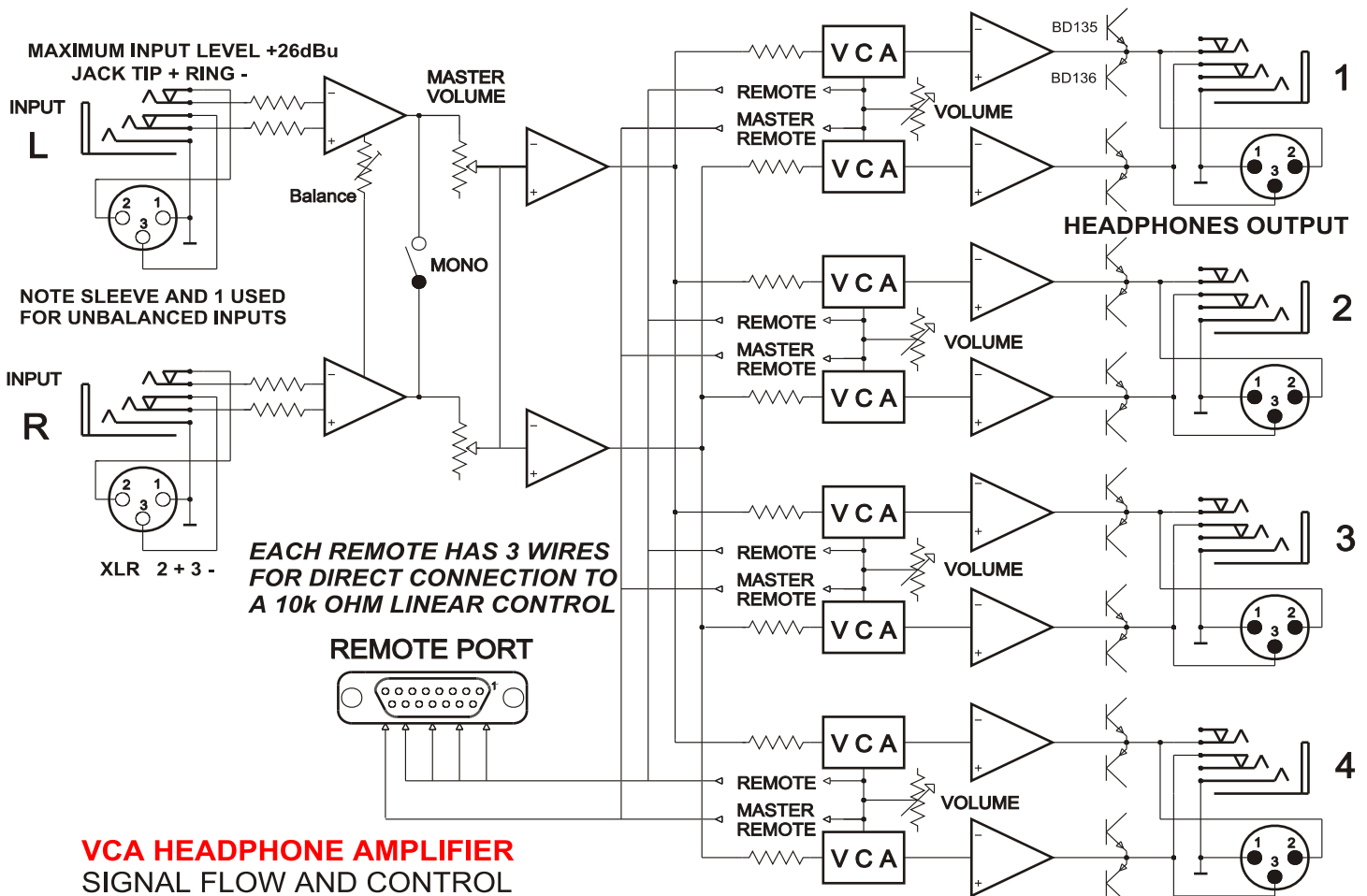
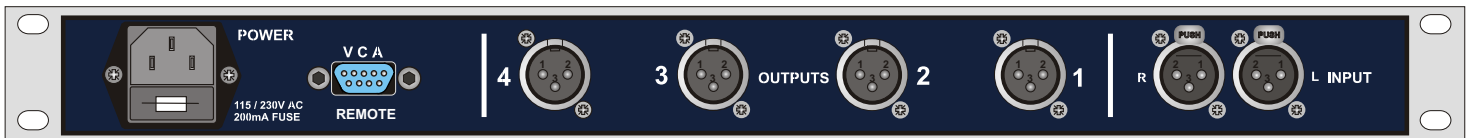

CHILTON VCA HEADPHONE AMPLIFIER

REMOTE PORT 15 WAY 'D' CONNECTOR

PIN 1	COMMON-PORT 1
PIN 9	WIPER-PORT 1
PIN 2	TOP OF LINEAR CONTROL-PORT 1 (off)
PIN 10	COMMON-PORT 2
PIN 3	WIPER-PORT 2
PIN 11	TOP OF LINEAR CONTROL-PORT 2 (off)
PIN 4	COMMON-PORT 3
PIN 12	WIPER-PORT 3
PIN 5	TOP OF LINEAR CONTROL-PORT 3 (off)
PIN 13	COMMON-PORT 4
PIN 6	WIPER-PORT 4
PIN 14	TOP OF LINEAR CONTROL-PORT 4 (off)
PIN 7	COMMON-MASTER VOLUME (off)
PIN 15	WIPER-MASTER VOLUME
PIN 8	TOP OF LINEAR CONTROL-MASTER VOLUME

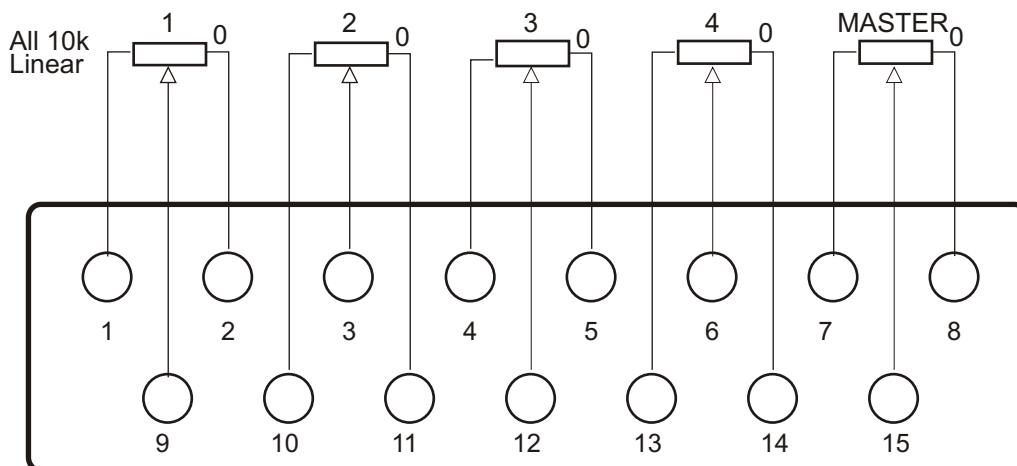

REMOTE PORT SOCKET VIEW

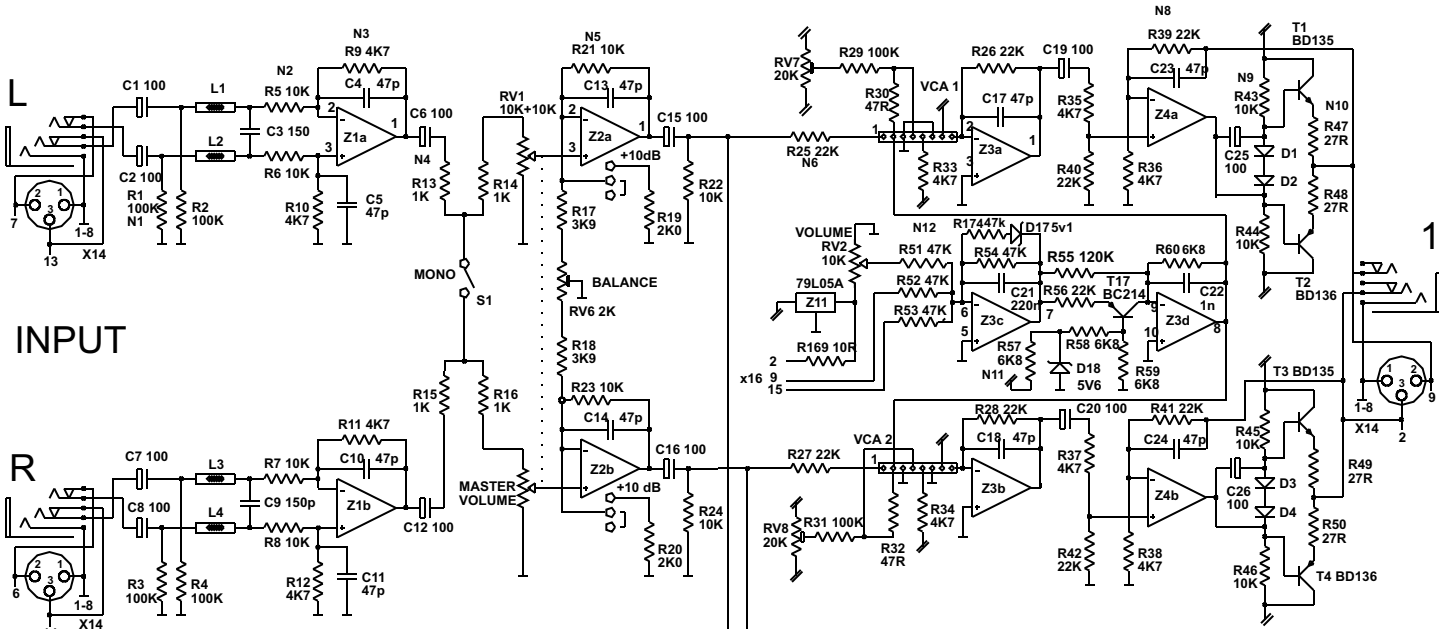

INPUT

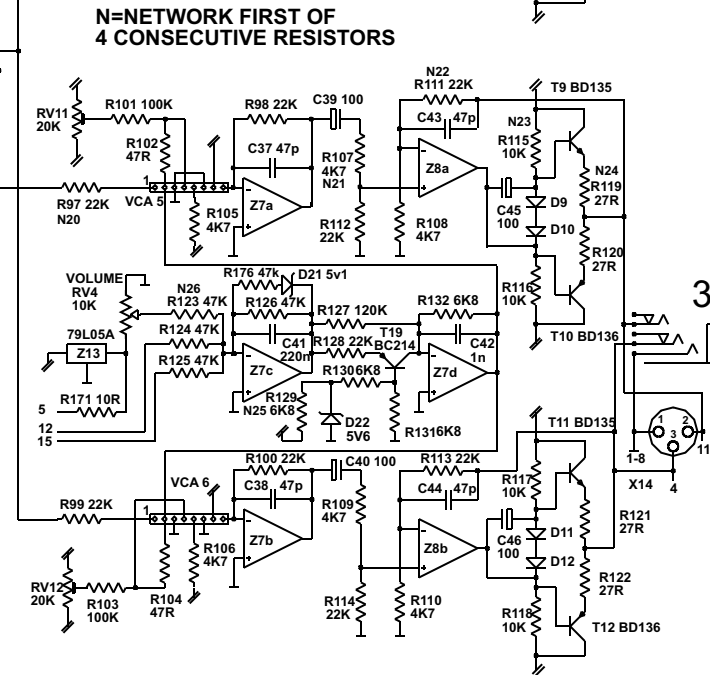
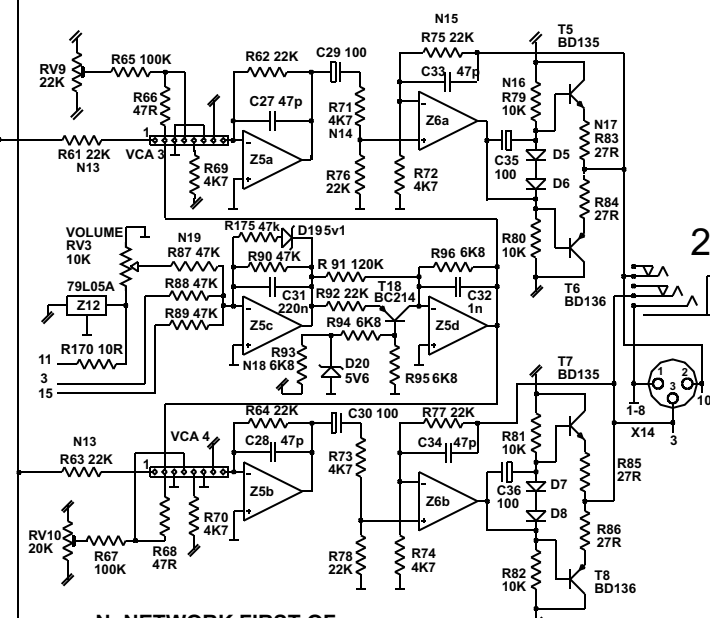
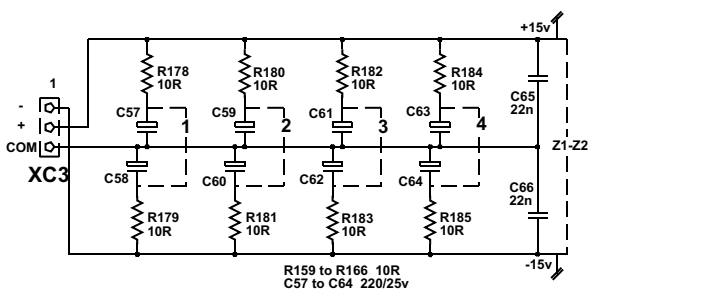
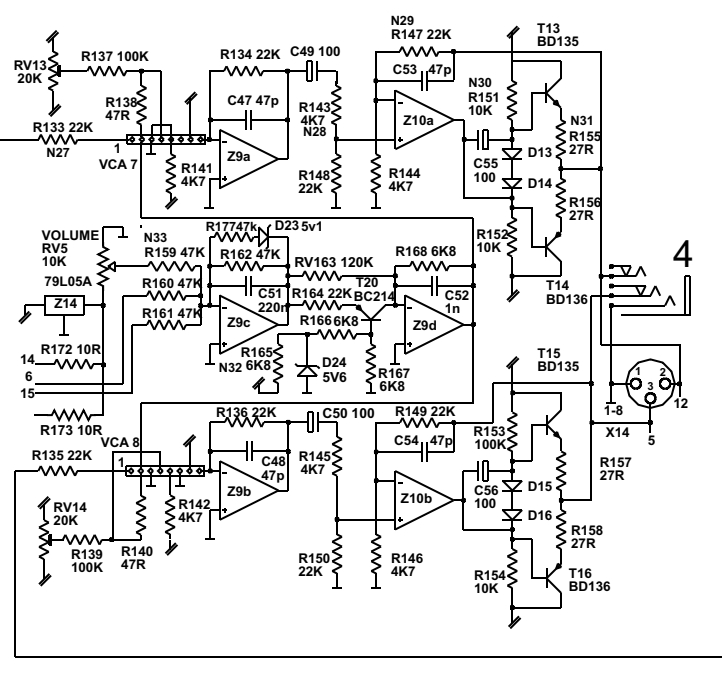

N=NETWORK FIRST OF 4 CONSECUTIVE RESISTORS

HEADPHONE DISTRIBUTION AMPLIFIER V.C.A. Version 3
revised 01-04-05

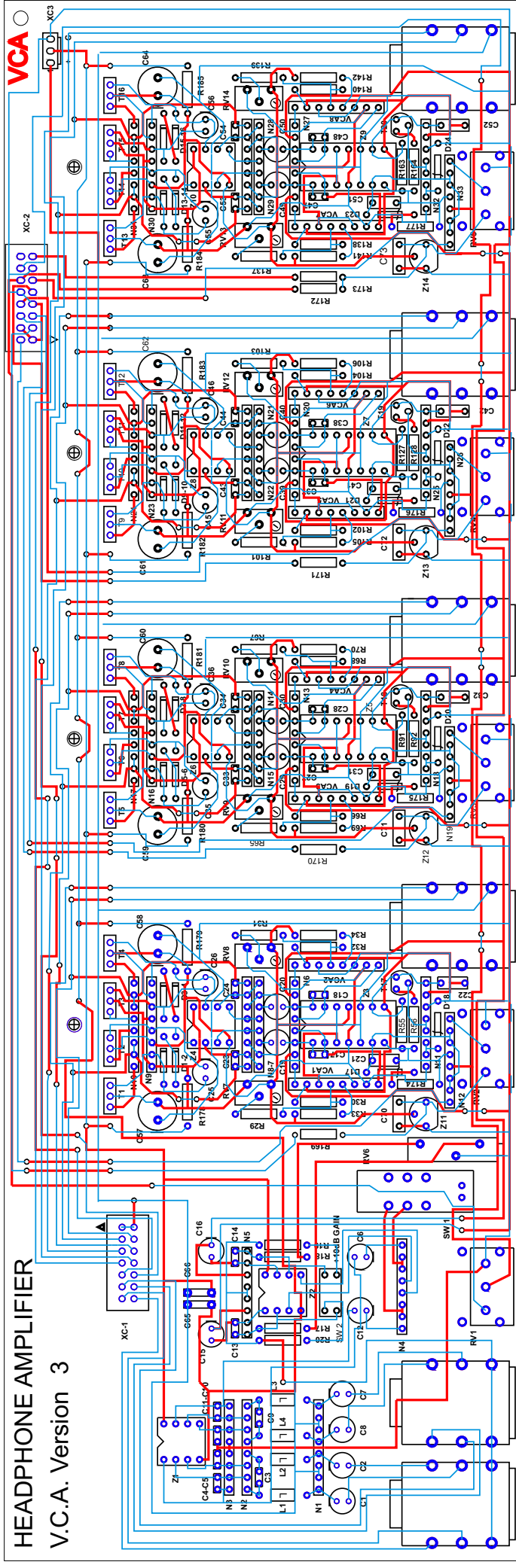

HEADPHONE AMPLIFIER
V.C.A. Version 3

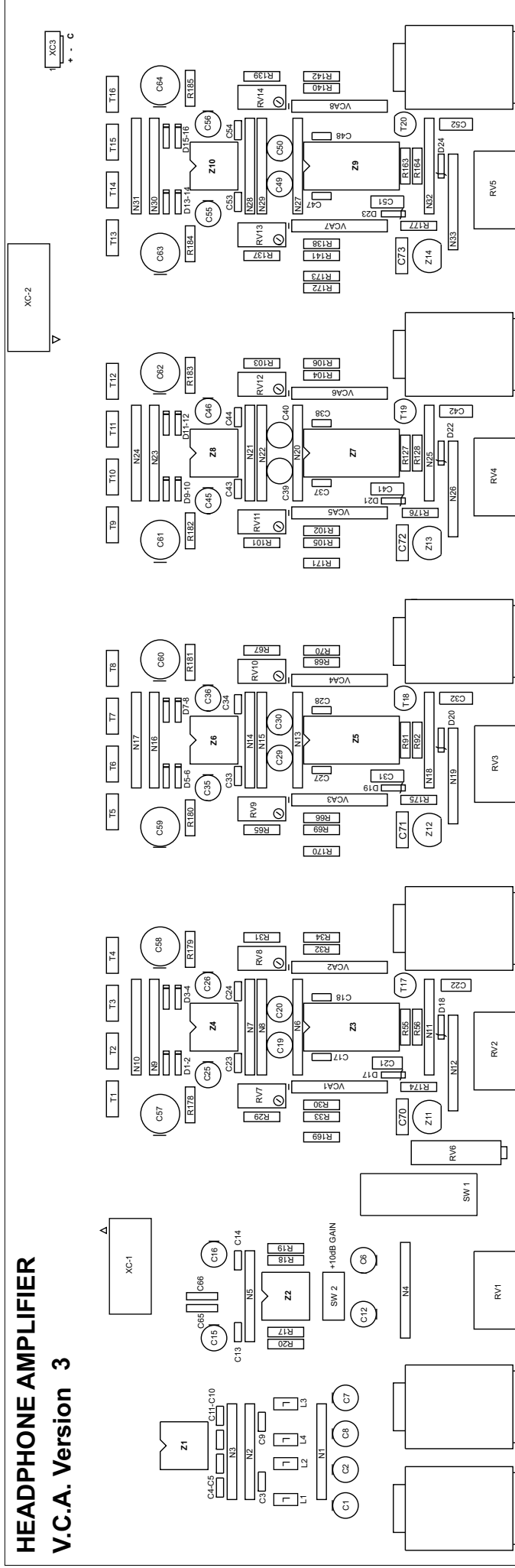

LEFT INPUT RIGHT

MASTER LEVEL MONO BAL

VOLUME 1

HP 1

VOLUME 2

HP 2

VOLUME 3

HP 3

VOLUME 4

HP 4

COMPONENT LAYOUT

PS +/-15V DC

T₁

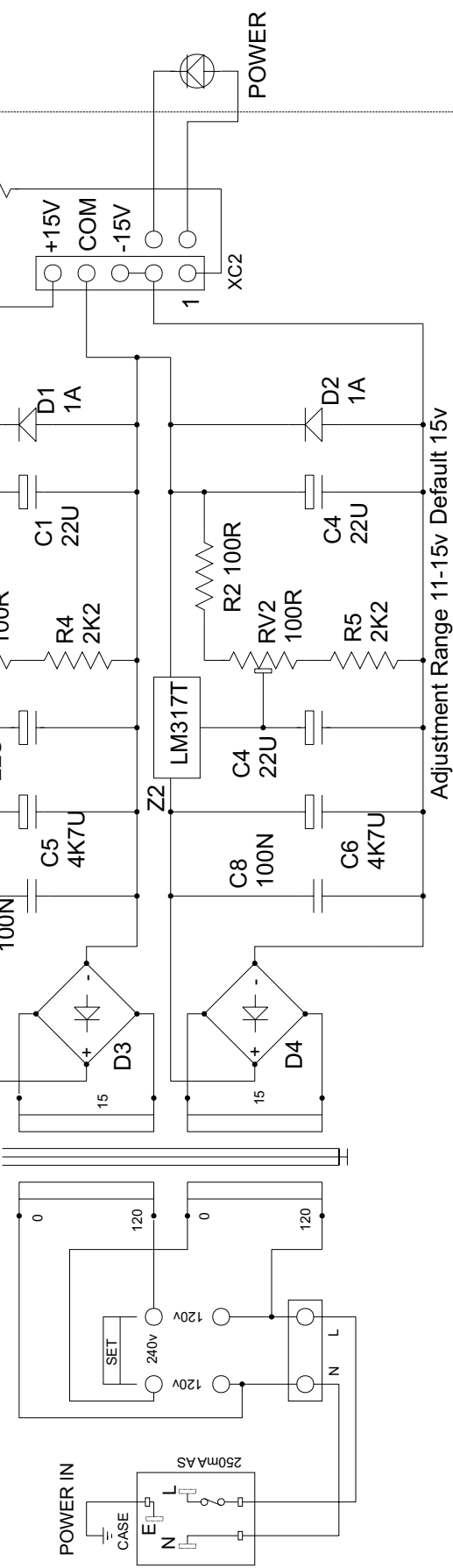

Adjustment Range 11-15v Default 15v

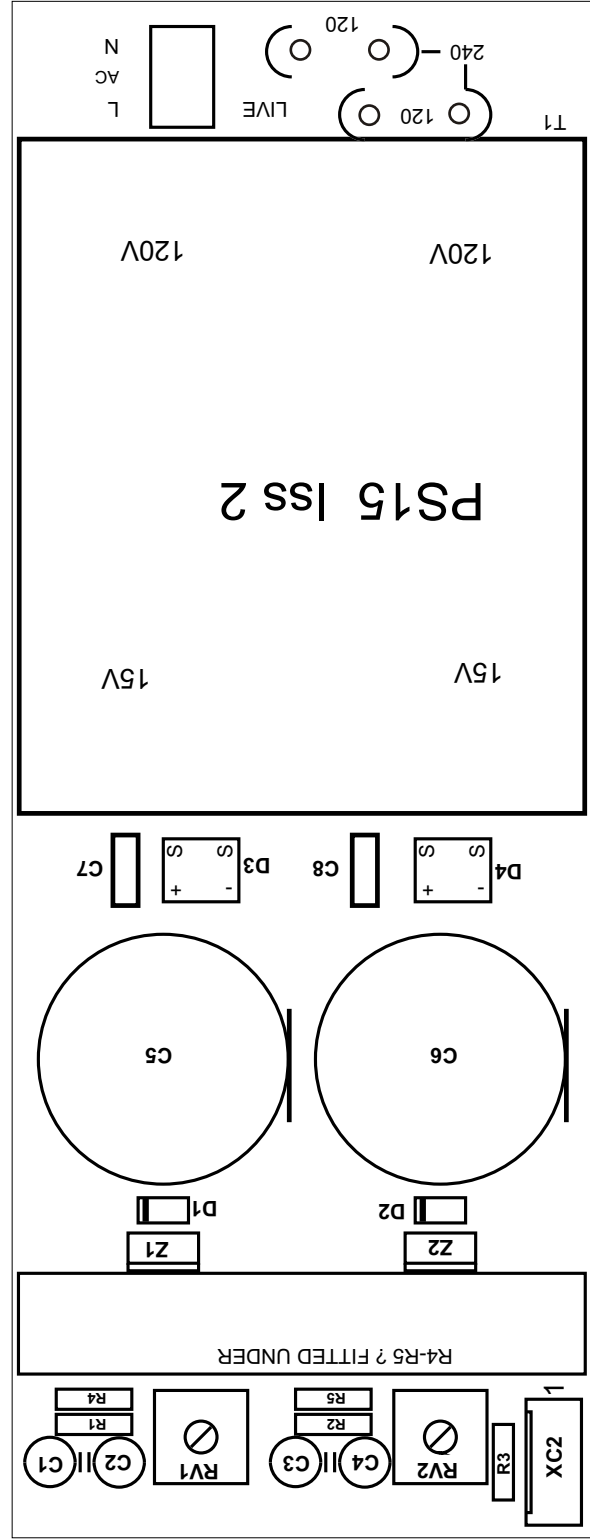

REGULATED POWER SUPPLY FOR CHILTON RACK UNITS

Headphone Distribution Amplifier PCB Parts List

Network Resistors 2% 8 Pin 4 Way

N1 = 100K R1 R4
N2 = 10K R5 R8
N3 = 4K7 R9 R12
N4 = 1K R13 R16
N5 = 10K R21 R24
N6 = 22K R25 R28
N7 = 4K7 R35 R38
N8 = 22K R39 R42
N9 = 10K R43 R46
N10= 47R R47 R50
N11= 6K8 R57 R50
N12= 47K R51 R54
N13= 22K R61 R64
N14= 4K7 R71 R74
N15= 22K R75 R78
N16= 10K R79 R82
N17= 47R R83 R86
N18= 6K8 R93 R96
N19= 47K R87 R90
N20= 22K R97 R100
N21= 4K7 R107 R110
N22= 22K R111 R114
N23= 10K R115 R118
N24= 47R R119 R122
N25= 6K8 R129 R132
N26= 47K R123 R126
N27= 22K R133 R136
N28= 4K7 R143 R146
N29= 22K R147 R150
N30= 10K R151 R154
N31= 47R R155 R158
N32= 6K8 R165 R168
N33= 47K R159 R162

Metal Film 1% MF25 0.25w

3K9= R17-18
2K0= R19-20
100K= R29-31-65-67-101-103-107-139
47R= R30-32-66-68-102-138-140
4K7= R33-34-69-70-105-106-141-R142
120K= R55-91-127-163
22K= R56-92-128-164
10R= R178-179-180-181-182-183-184-185-169-170-171-172-173
47K= R174-175-176-177
20K= RV7-8-9-10-11-12-13-14 Multi Turn P.N. PV36
Potentiometer 22k+22k Log = RV1
Potentiometer 10k Linear = RV2-3-4-5 (dual may be fitted on certain batches)

Inductors

100uH= L1-2-3-4 P.No. MAL3

Capacitors

100uF/10v= C1-2-6-7-8-12-15-19-19-20-25-26-29-30-3536-39-40-45-49-50-55-56 105c Electrolytic 2.5mm
220uF/25v= C57-58-59-60-61-62-63-64 85c Electrolytic 4mm
150pF/100v= C3-9 Type N150 2% 2.5mm
47pF/100v= C4-5-10-11-13-14-17-18-23-24-27-28-33-34-37-38-43-44-47-48-53-54 Type N150 2% 2.5mm
220n/100v= C21-31-41-51 Polyester Film 5mm
1n/250v= C22-32-42-52 Polyester Film 5mm

Semiconductors

Voltage Controlled Amplifier= VCA1-VCA8 Type THAT 2181LC

Generic Types:

NE5532= Z1-2
TLO72 = Z4-6-8-10
TLO74= Z3-5-7-9
79L05ACP= Z11-12-13-14
BC214c= T17-18-19-20
BD135= T1-3-5-7-9-11-13-15
BD136= T2-4-6-8-10-12-14-16
IN4181= D1-D16
Zener 5v1= D17-19-21-23 BZX79C
Zener 5v6= D18-20-22-24 BZX79C

Connectors

Jack Sockets Switched 3 Pole S2 BBB BLK PCA A Total 6
14 Way Male Header XC-1 (audio in/out)
16 Way Male Header XC-2 +Female Connector (remote)
3 Way Male Header XC-3 + Female Connector (supply)
XLR Female Connector 2 off Neutrik NC3FDM3-H
XLR Male Connector 4 off Neutrik NC3MDM3-H
15 Way Female 'D' Connector (remote)

CHILTON VCA HEADPHONE AMPLIFIER

REMOTE PORT 15 WAY 'D' CONNECTOR

PIN 1	COMMON-PORT 1
PIN 9	WIPER-PORT 1
PIN 2	TOP OF LINEAR CONTROL-PORT 1 (off)
PIN 10	COMMON-PORT 2
PIN 3	WIPER-PORT 2
PIN 11	TOP OF LINEAR CONTROL-PORT 2 (off)
PIN 4	COMMON-PORT 3
PIN 12	WIPER-PORT 3
PIN 5	TOP OF LINEAR CONTROL-PORT 3 (off)
PIN 13	COMMON-PORT 4
PIN 6	WIPER-PORT 4
PIN 14	TOP OF LINEAR CONTROL-PORT 4 (off)
PIN 7	COMMON-MASTER VOLUME (off)
PIN 15	WIPER-MASTER VOLUME
PIN 8	TOP OF LINEAR CONTROL-MASTER VOLUME

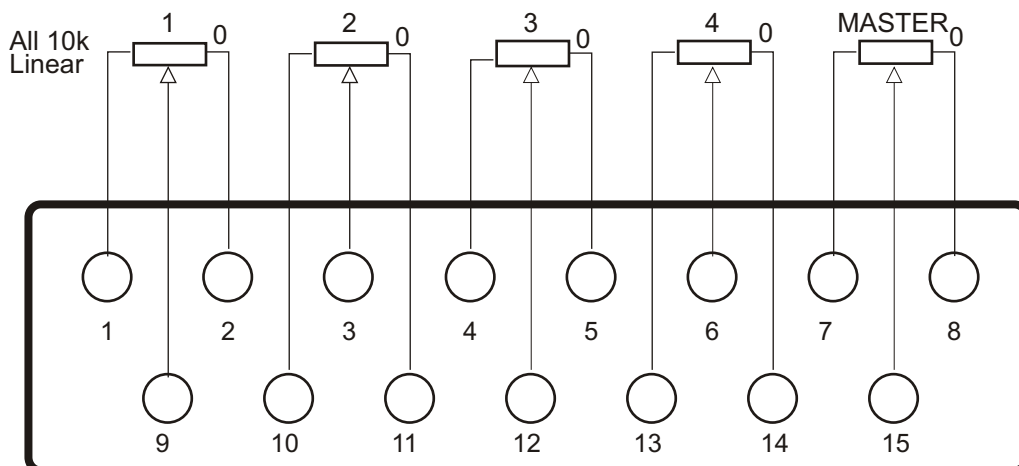

REMOTE PORT SOCKET VIEW